

WALKING BEAM AND SWITCH KITS

Switch Kits Include:

2 ea weld fittings (saddle style), 2 ea #6 sae stainless steel 2000 wog locking ball valves, directional control valve with 115v control, subplate, bolt kits, assembly labor, hydraulic cylinder 1-1/2 x 2" 1500 psi epoxy coated, clevis, associated hydraulic fittings, and 4' hoses.

Notes

Weld fittings are saddle style, hole is drilled in pipe and fitting placed on pipe and welded in place. We can prefabricate headers or provide additional instructions if requested. Standard Headers will be provided with fittings on 36" centers.

Hydraulic fittings between ball valve and header are o ring unions, ball valve to valve are 90 degree o ring to JIC male, valve manifold fittings are all straight oring to JIC male, cylinder fittings 90 degree o ring to male jic. All fittings #6 o ring and #6 JIC male. Fitting at P port of valve is an orifice fitting for speed control.

Cylinder is an 1-1/2" bore 2" stroke cushioned both sides, clevis mount, 1500 psi cylinder Orifice is drilled in piston to provide movement of oil for warming. With orifice installed 2 position valve required to provide oil warming.

Valve to be 115V conduit connection. Customer to specify 2 position detent, 2 position spring offset, or 3 position spring center. Note if 3 position valve is used you will not use warming circuit.

Hoses to be 4' unless otherwise specified. Different lengths provided upon request. May change pricing of kit.

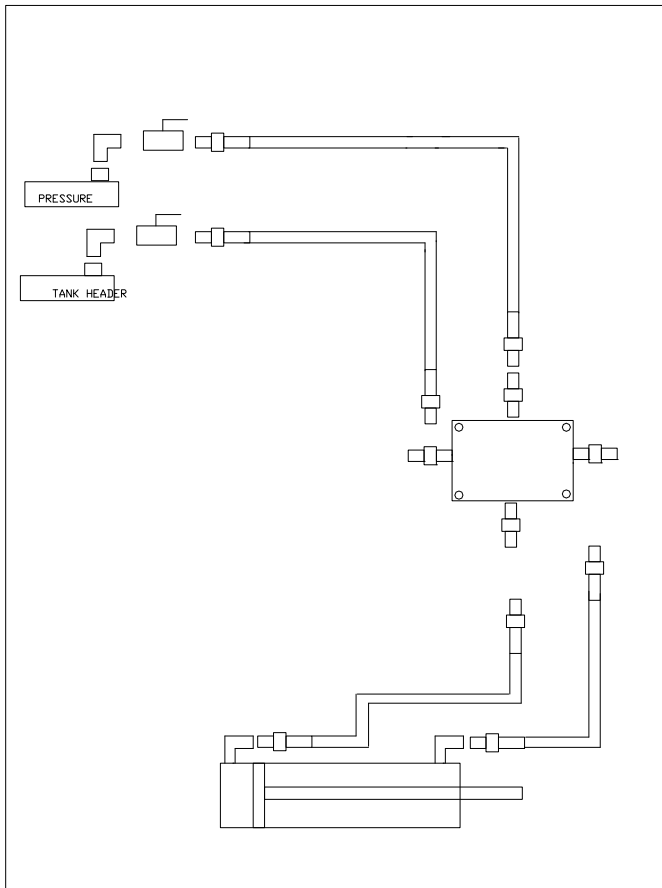

Quantity discounts available

